



# 275 VX — 350 VX

from the industry-leading innovator



[RING-O-MATIC.COM](http://RING-O-MATIC.COM)

# MACHINE SPECIFICATIONS

FEATURES	275 VX	350 VX
Mountings	Trailer, Truck & Skid mounting	Trailer, Truck & Skid mounting
Spoils Capacity (gallons / liters)	250 gallons / 946 liters	350 gallons / 1592 liters
Water Capacity (gallons / liters)	100 gallons / 378 liters	100 gallons / 378 liters
Optimum & Balanced Tongue Weight	1,000 lbs	1,000 lbs
Engine	Tier 4F Industrial Diesel	Tier 4F Industrial Diesel
Fuel Tank Capacity (gallons / liters)	29 gallons / 110 liters	29 gallons / 110 liters
Dual LED work lights and strobe	Standard	Standard
Warranty	One Year	One Year
OPERATOR CONTROLS		
Controls Location	Front curbside with lockable cabinet	Front curbside with lockable cabinet
Hour Meter / Tachometer / Vacuum Gauge	Standard	Standard
Water Supply Reel	Rear Curbside	Rear Curbside
Load Level Indicator and Auto Shutoff	Sight Glass & Auto Shutoff	Sight Glass & Auto Shutoff
Reverse Flow	Standard	Standard
SPOILS TANK DETAILS		
Hydraulic Hoist Unload	Single cylinder	Single cylinder
Full Opening Rear Door	Hydraulically operated	Hydraulically operated
Rear Door Latch	Manual	Manual, Power Door Lock Optional
Inlet Valve Size / Drain Valve Size	4" / 4"	4" / 4"
TRAILER DETAILS - HEAVY DUTY 4" C-CHANNEL FRAME		
Trailer / Hitch Type	Single Axle (Dual Axle Option) / Pintle	Single Axle (Dual Axle Option) / Pintle
Trailer Height x Length x Width (in / m)	86" x 185" x 86" / 2.2 x 4.7 x 2.2	86" x 190" x 86" / 2.2 x 4.8 x 2.2
Trailer Empty Weight (lbs / kg)	4,300 lbs / 1950 kg	4,500 lbs / 2041 kg
Gross Vehicle Weight Rating	7,500 lbs / 3629 kg	7,500 lbs / 3629 kg
Axles, Capacity and Suspension Type	7,000 lb Dexter Torflex	7,000 lb Dexter Torflex
Tire Size	ST235/80 R16 Load Range E	ST235/80 R16 Load Range E
Trailer Brakes	Never adjust electric	Never adjust electric
Skid Mount - Height x Length x Width (in / m)	67" x 140" x 79" / 1.7 x 3.6 x 2	67" x 145" x 79" / 1.7 x 3.7 x 2
Skid Mount - Empty Weight (lbs / kg)	3,700 lbs / 1678 kg	3,900 lbs / 1769 kg
VACUUM PUMP/BLOWER DETAILS		
Vacuum Pump / Blower Type	Positive displacement lobe pump	Positive displacement lobe pump
CFM / Max Hg	600 CFM / 15"	600 CFM / 15" or 1,000 CFM / 15"
Reverse Flow	Standard	Standard
Air Filter Type / Capacity	Cyclonic-Action through a .3 micron filter, 106ft <sup>2</sup> capacity	Cyclonic-Action through a .3 micron filter, 106ft <sup>2</sup> capacity
WATER SYSTEM DETAILS		
Water Pressure / Water Supply	4,000 psi *factory set @ 3,500 psi / 6 gpm	4,000 psi *factory set @ 3,500 psi / 6 gpm
Electronic Low Water Shut-Off	Standard	Standard
Auto Water Pump Unloader to Reduce Engine Loading & Wear	Standard	Standard
Water Pump Drive	Belt w/ Electric Clutch	Belt w/ Electric Clutch
Water Supply Hose	50' x 3/8" ID	50' x 3/8" ID
Water Supply Reel Location	Rear Curbside	Rear Curbside
Easy-to-Use Winterize System	Standard	Standard
OPTIONS		
Patented Viper Pothole Tool – Stainless or Dielectric	Recommended	Recommended
Curbside Remote Auxiliary Hydraulics	Optional	Optional
Lighted Arrow Bar to Direct Traffic	Optional	Optional
Manual Boom	Optional	Optional
Removable Water Heater	Optional	Optional
In Tank Clean Out System	Optional	Optional
Power Door Lock	Not Available	Optional

ALL WEIGHTS AND DIMENSIONS ARE ENGINEERING ESTIMATES.



# KEY FEATURES

## COMPACT



THE COMPACT DESIGN OF THE 275VX AND 350VX ALLOWS THEM TO BE USED FOR MULTIPLE APPLICATIONS WHILE DELIVERING THE SAME POWER OF THE STANDARD 550VX AND 850VX MACHINES.

## 1/2 TON TOW-ABLE

A 1/2 TON PICK-UP IS MORE THAN ENOUGH TO PULL THE 275VX. CHOOSE BETWEEN A SINGLE AXLE OR DUAL AXLES TO BEST FIT YOUR TOWING POWER.



## REVERSE FLOW



THE 275VX AND 350VX OFFERS REVERSE FLOW STANDARD, WHICH ALLOWS YOU TO PRESSURIZE THE TANK FOR EASY OFFLOADING AND ASSISTS IN CLEARING HOSE OBSTRUCTIONS.

## SPIDER DOOR LOCK

THE SPIDER DOOR LOCK IS THE MARKET'S BEST MANUAL DOOR OPTION AND ALLOWS THE MACHINE TO DO THE WORK WHILE THE OPERATOR ONLY NEEDS TO ACTUATE AN EASY PULL LEVER.



## VIPER TOOL



THE PATENTED VIPER POTHOLE TOOL DELIVERS UNMATCHED PERFORMANCE ON THE JOBSITE. THIS COMBINATION OF THE DIGGING LANCE AND SUCTION TUBE MAKES WORK EASY AND CLEAN.



## CONTRACTOR GRADE FOR THE HOME OWNER.

THE RING-O-MATIC 275VX AND 350VX OFFER THE SAME POWER AS OUR LARGER UNITS WITHIN A COMPACT DESIGN AND A SMALLER PRICE TAG. THE 275VX AND 350VX ARE PERFECT MACHINES FOR MANY APPLICATIONS FROM PUTTING IN FENCE POSTS TO MID TO LARGE SCALE LANDSCAPING JOBS. THESE MACHINES SHOWCASES THE WIDE VARIETY OF OUR EQUIPMENT LINE UP AND CAN BE USED FOR TRADITIONAL POT HOLING AND SLOT TRENCHING AS WELL. THE 275VX AND 350VX ARE INDEED A CONTRACTOR MACHINE FOR THE AVERAGE HOME OWNER.

## APPLICATIONS:

ANIMAL WASTE CLEANUP  
CAR WASH PIT CLEANING  
CATCH BASIN CLEANING  
CEMETERY HEADSTONE RESETTING  
CITY UTILITY MAINTENANCE  
MUNICIPALITY USE  
CONCRETE SLURRY MANAGEMENT  
DAIRY FARM CLEAN UP  
DAYLIGHTING  
FENCE POST SETTING  
FERTILIZER PLANT CLEANUP  
FOUNDATION STABILIZATION  
GRAIN ELEVATOR CLEANUP  
HURRICANE CLEANUP  
HYDRO EXCAVATION  
LIFT STATION CLEANING  
LOCATING UNDERGROUND UTILITIES

MANHOLE CLEANUP / MAINTENANCE  
MICRO-TUNNELING  
MUD REMOVAL  
POND CLEANUP  
POT HOLING  
PRECISE LANDSCAPING  
RETENTION POND CLEANING  
ROAD SIGN SETTING  
SILO CLEANING  
SLOT TRENCHING  
SLURRY REMOVAL  
STALL CLEANING  
STORM DRAIN CLEANING  
TREATMENT PLANT CLEANING  
UTILITY POLE SETTING  
WATER VALVE CLEANING  
WET / DRY REMOVAL



800.544.2518

# 275 VX — 350 VX

275VX SKID

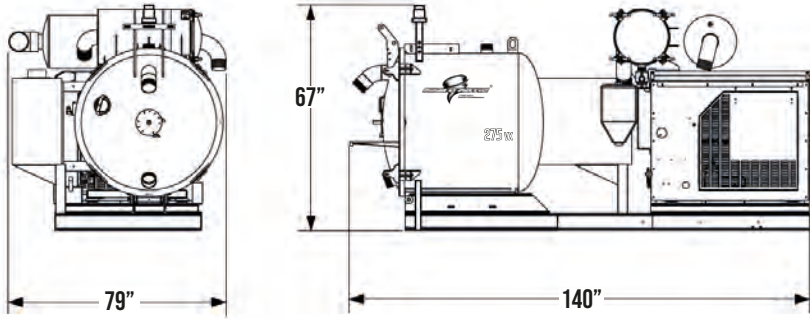

275VX TRAILER

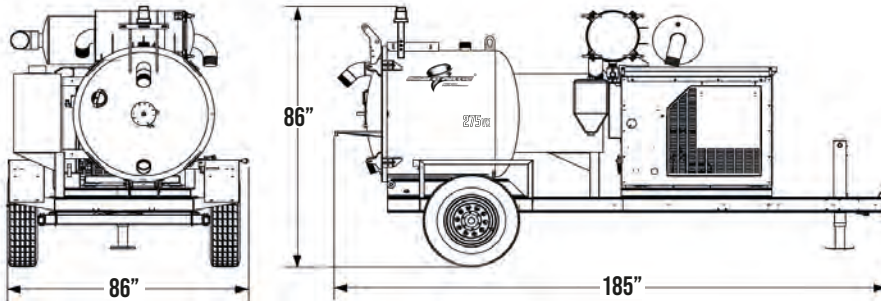

350VX SKID

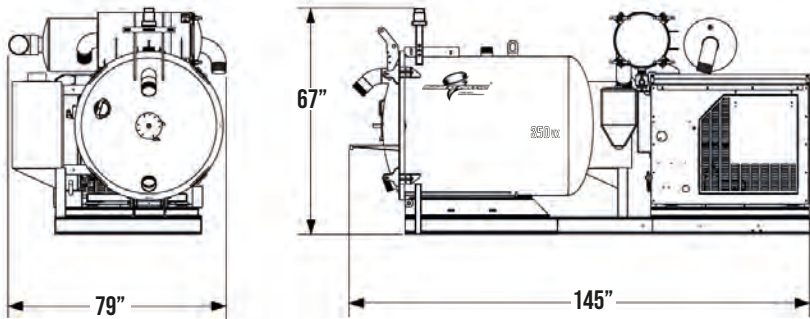

350VX TRAILER

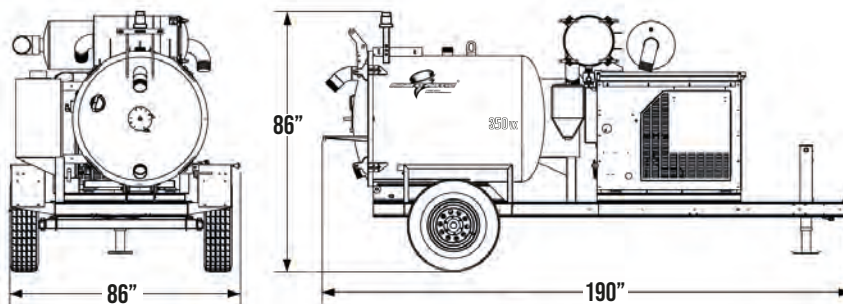

**FOR ALL TRUCK MOUNT  
SPECIFICATIONS  
PLEASE CONTACT OUR  
SALES DEPARTMENT @  
800-544-2518**



ALL DIMENSIONS ARE IN INCHES. DIMENSIONS ARE ENGINEERING ESTIMATES



1714 FIFIELD ROAD  
PELLA, IOWA 50219

All equipment shown is for illustrative purposes only and may display optional accessories or components. Please contact your local Ring-O-Matic dealer or Corporate sales team for more information about machine specifications. Ring-O-Matic reserves the right to make changes in engineering, design and specifications; add improvements; or discontinue manufacturing at any time without notice or obligation. RING-O-MATIC, RING-O-MATIC Corporate logo, Ring-O-Matic Company R logo, PROVEN PERFORMANCE and VIPER are trademarks of Ring-O-Matic, INC. in the U.S. and / or other countries.